

Objective

The objective of this application note is to (1) illustrate the use of Intersil's digitally controlled potentiometers (XDCPs) to automate the control of the key parameters of sensor circuits and (2) provide the design engineer with reference designs.

Description

Sensors are energy conversion devices. Sensors or transducers convert the physical world of light, pressure, temperature, flow, level, acceleration, force, etc. to electrical signals but generally they can't do so without help. Excitation and/or signal conditioning electronics are almost always needed to interface the sensor and provide adjustable calibration, amplification, linearization, and level transformation functions.

Digitally controlled potentiometers add variability and programmability to the sensor circuit and provide an automated alternative to manually adjusted mechanical trimmers. The results are accuracy, speed, reliability, packaging flexibility, and labor and cost savings.

The following three circuits illustrate the use of the digitally controlled potentiometer in sensor circuits. In a photodiode's *transimpedance amplifier*, one XDCP provides for the adjustment of a wide range current-to-voltage conversion function while a second XDCP provides a precision zero trim. Two digitally controlled potentiometers provide for the zero adjust and full scale adjust features of a *pressure transducer signal conditioning circuit*. Similarly, two potentiometers provide the zero adjust and full scale adjust features of a *thermometer circuit using a platinum resistance temperature detector*. These circuits illustrate basic ideas in the design of sensor circuits and are but a small sampling of the many potential applications in this area.

Photovoltaic Transimpedance Amplifier

Photovoltaic detectors are used to sense and measure light energy in industrial, medical, consumer, and scientific instrumentation applications. Solid state photovoltaics respond to wavelengths ranging from the far infra-red through the visible spectrum and into the ultra-violet and therefore tend to excel in precision photometric applications. This versatility suits photovoltaics to such diverse jobs as chemical spectral analysis, colorimetry, non-contact thermometry, flame detection, and non-invasive blood-gas monitoring.

The basic signal conditioning circuit for photovoltaics is the current-to-voltage or transimpedance amplifier of Figure 1. The chief shortcoming of this classic circuit is the inability of one value of feedback resistor to adequately accommodate the four, five, or more decades of dynamic range of current produced by many of the photo detectors. Even when R_F is made adjustable, the finite resolution of the feedback resistance fails to fully resolve the dynamic range problem.

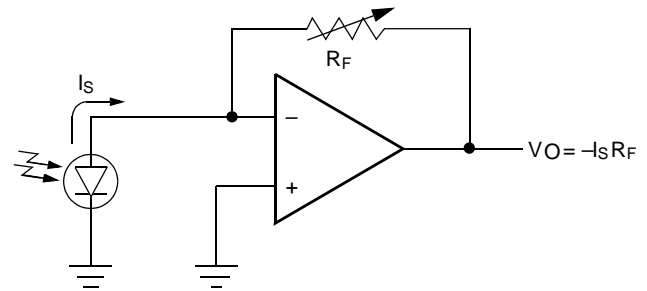

FIGURE 1. TRANSIMPEDANCE AMPLIFIER

The circuit of Figure 2 combines two Intersil X9258T digitally controlled potentiometers with an AD822 low-noise dual opamp to create a flexible, digitally calibrated, wide dynamic range transimpedance amplifier topology that can be used with virtually any photovoltaic detector technology. The amplifier output is given by:

$$V_O = I_S(1M\Omega) \frac{1 + P1}{256 - P1}$$

where P1 is the 8-bit (0 to 255) digital value written to DCP1.

Of particular interest is the pseudo-logarithmic behavior of the circuit's transimpedance gain as a function of P1. The transimpedance gain of this amplifier varies over the range of 1/256 megohm to 256 megohm as the programming of DCP1 varies from 0 to 255 while gain-factor resolution never gets worse than 10% per P1 increment over an 400:1 (52dB or nearly 9 bit) range of 50K to 20M Ω . Transimpedance settings covering an even wider span are accessible, 4K to 256M Ω corresponding to fullscale I_S values from 1mA to 16nA, albeit with reduced resolution. A linear gain adjustment cannot achieve both a multi-decade gain adjustment range and good adjustment resolution throughout the range.

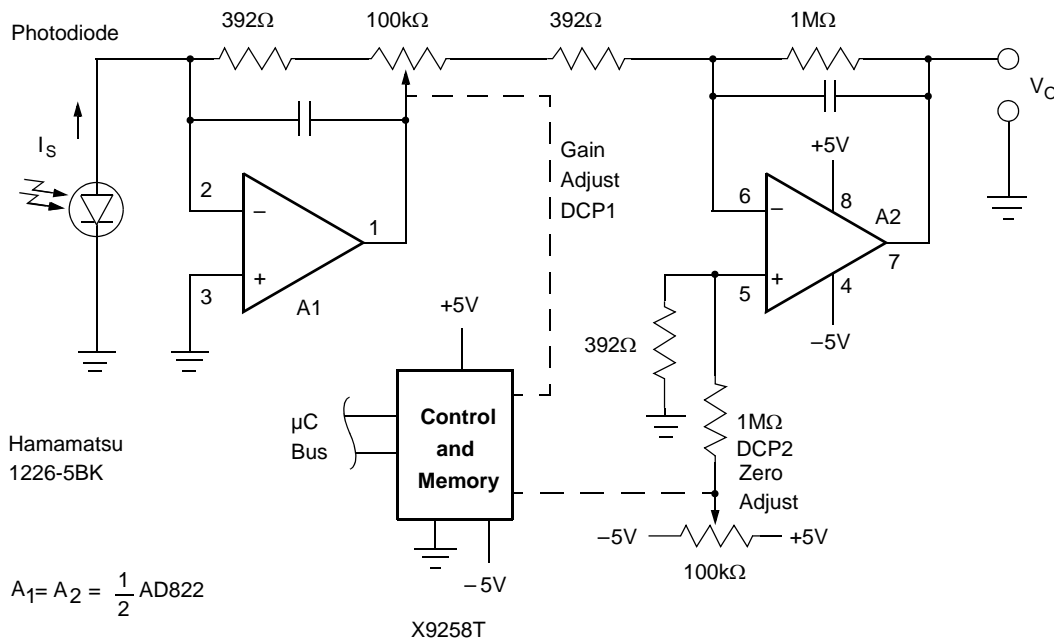

FIGURE 2. PROGRAMMABLE TRANSIMPEDANCE AMPLIFIER

A second feature of the circuit in Figure 2 is the independence of gain of both DCP1 element and wiper resistances. Using the pot wiper as an input terminal effectively moves element tempco and wiper contact resistance errors inside the feedback loop of A1, thus removing them as gain-error terms and thus improving the time and temperature stability of the gain setting.

DCP2 is used to null the amplifier zero point. It varies the voltage at the noninverting input of A2 by $\pm 2\text{mV}$ with a resolution of $16\mu\text{V}$.

Programmable Pressure Transducer Circuit

The silicon piezoresistive-bridge pressure transducer (SPPT) is a dominant technology in automotive, industrial, medical, and environmental pressure sensor applications. All SPPTs share a similar architecture in which a thin (5 to $200\mu\text{m}$) micromachined silicon diaphragm incorporates an implanted piezoresistive Wheatstone-bridge strain-gauge. Applied pressure bends the diaphragm, imbalances the strain gauge, and thereby produces a differential output signal proportional to the product of pressure times bridge excitation voltage.

SPPTs must be supported by appropriate signal conditioning and calibration circuits. Finite elasticity limits the SPPT diaphragm to relatively small deflections which generate only $\pm 1\%$ modulation of the bridge resistance elements and low signal output levels, creating the need for high gain, low-noise, temperature-stable DC amplification. The signal conditioning circuit must also include stable, high resolution, preferably non-interactive, zero and span trims. The automation of the

calibration of the sensor circuit is an enormous benefit in the production environment.

Another complication of SPPT application is the large temperature dependence of both total bridge resistance and peizosensitivity (the ratio of bridge output to excitation voltage times pressure). Bridge resistance increases with temperature while peizosensitivity decreases. Some SPPT designs (e.g. the Lucas NPC-410 series) carefully equalize these opposite-sign tempcos. The payoff comes when such SPPTs are excited with constant current because the increase with temperature of bridge resistance (and therefore of bridge excitation voltage) then cancels the simultaneous decrease of peizosensitivity.

Ordinarily, a $\sim 10\text{mV/psi}$ pressure-proportional strain gauge signal is output differentially on pins 2 and 4 of the sensor, superimposed on the ~ 50 times larger bridge excitation voltage. The standard method for separating the bridge's differential pressure signal from the common mode bias voltage would be to use an expensive, high performance differential amplifier. Figure 3 employs a different scheme. The bridge is current-biased and two amplifiers and two digitally controlled potentiometers provide for zero and full scale (gain) adjustments. The output of A2 drives the bottom of the bridge until pin 4 output of the bridge is at a programmable voltage near zero volts. With pin 4 at zero volts, pin 2 can be treated as a single ended or ground referenced voltage. Pin 2 of the bridge output is then amplified by the noninverting A3 amplifier circuit.

In the detailed circuit of Figure 4, the A2 circuit provides for the precision adjustment, via DCP1, of any transducer initial null offset error. To accomplish this, the bridge excitation voltage is programmably attenuated by the R2, R3, R4, R5 network and applied to DCP1. The range for the zero adjustment voltage is from +22mV to -22mV. The resolution is 172µV and is proportional to the bridge excitation voltage, thus improving the temperature stability of the zero adjustment. Boosting the ~10mV/psi bridge signal by 100x to a convenient 1V/psi output level is the job of the A3 noninverting amplifier via its feedback and calibration network consisting of R7 through R9 and DCP2. The gain of A3 can be varied from 75 to 125 with a resolution of 0.2. Bridge bias is provided by the A1 circuit which uses voltage reference D1 and current-sense resistor R1 to generate a constant-current bridge drive of $I = 1.225V / 2k\Omega = 612\mu A$.

The net result of the combination of transducer and the Figure 4 circuitry is a signal conditioned precision pressure sensor that is compatible (thanks to DCP1 and 2) with full automation of the calibration process, is very low in total power draw (< 1 milliampere, most of which goes to transducer excitation), and (equally important) is low in cost.

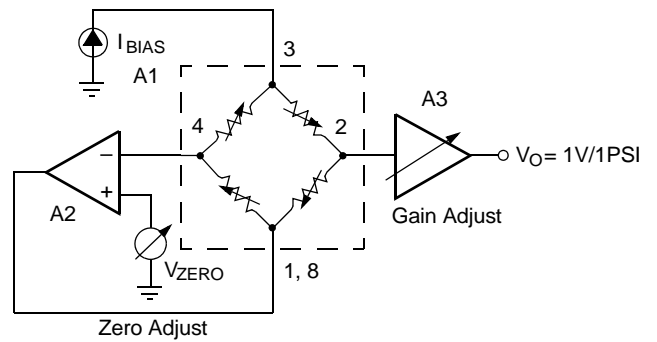

FIGURE 3. PRESSURE TRANSDUCER SIGNAL CONDITIONING CIRCUIT – SIMPLIFIED

PRTD Signal Conditioning Circuit

Among temperature transducers, the platinum resistance temperature detector (PRTD) is generally accepted as the 'gold standard'. PRTDs are ubiquitous and find wide application in the aviation, environmental, industrial, and scientific instrumentation areas. The circuit in Figure 5 uses the PRTD in a bridge circuit whose output is amplified by a high performance instrumentation amplifier (IA). Amongst the problems associated with this traditional approach is the lack of variability to account for sensor variations, lack of a linearization scheme, and the high cost of the instrumentation amplifier.

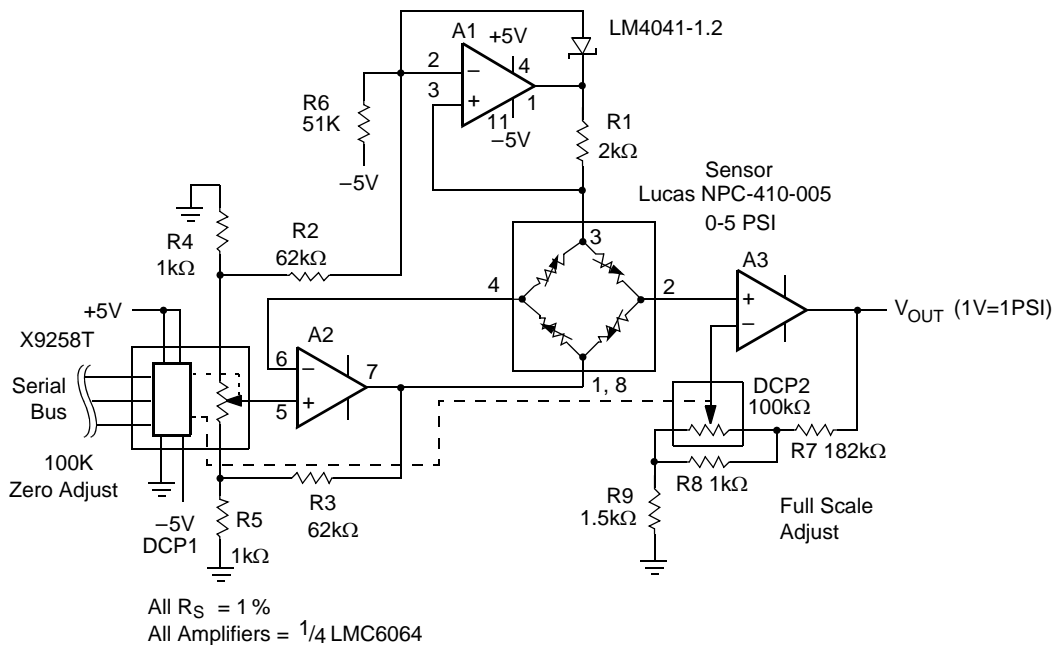

FIGURE 4. PRESSURE TRANSDUCER SIGNAL CONDITIONING CIRCUIT – DETAILED

The PRTD temperature response consists of resistance variations of the order of only tenths of ohms/°C. Hence strict attention must be paid to the effects of transducer lead wire resistance. The magnitude of the excitation current must also be severely limited, otherwise excessive I^2R PRTD power dissipation will cause unacceptably large self-heating measurement errors. Low excitation currents and small resistance changes combine to mean that the signal developed by the PRTD will typically be of the order of tens of $\mu\text{V}/^\circ\text{C}$ generating a requirement for stable high gain DC amplification in the signal chain. In addition, the PRTD temperature coefficient is only 'reasonably' invariant with temperature and, as a result, the PRTD's response is significantly nonlinear. The accurate measurement of temperature over a wide range depends on the provision for linearization of the PRTD signal. These design considerations are incorporated in the circuit of Figure 6 and result in a precision thermometer with output span of -1V to $+3.5\text{V}$ corresponding to a temperature range of -100 to $+350^\circ\text{C}$. The maximum error over this span can be adjusted to $\pm 0.02^\circ\text{C}$ at 0°C and $\pm 0.05^\circ\text{C}$ elsewhere.

Current excitation (approximately $250\mu\text{A}$) for the PRTD is sourced by the 2.5V voltage reference VR1 via R1. The 256 tap digitally controlled potentiometer DCP1 provides for automated adjustment of the thermometer scale factor and span. A1 is a noninverting amplifier

with a gain of 100 which scales up the raw $100\mu\text{V}/^\circ\text{C}$ PRTD temperature signal to $0.01\text{V}/^\circ\text{C}$. The DCP2 network implements a high resolution zero adjustment. Each increment in DCP2's setting will result in a $200\mu\text{V}$ shift in A1's output which is equivalent to a 0.02°C zero adjustment. The symmetry of the R6-R9 network surrounding DCP2 causes zero adjustment to have no effect on A1's gain and therefore no effect on the thermometer's span/scale factor. Likewise, span adjustments via changes in the VR1 reference allow no interaction between DCP1 and the zero calibration established by DCP2.

Positive feedback provided by R2 linearizes the thermometer's response curve by providing a Thevenin equivalent of a negative amplifier input resistance of -2064Ω in parallel with R1. This introduces a positive gain slope (roughly $+0.016\%/^\circ\text{C}$) which effectively cancels the tendency of the PRTD temperature coefficient to decline with increasing temperature. The result is better than a factor of 100 improvement in linearity over the raw PRTD response.

The net result of the combination of A1 and the associated circuit is a signal conditioning, precision temperature sensor that is compatible (thanks to DCP1 and 2) with full automation of the calibration process, low in total power draw, and low in cost.

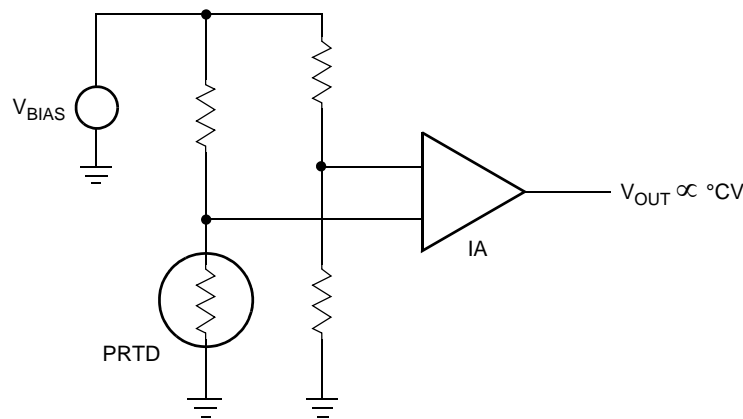

FIGURE 5. PRTD SENSOR CIRCUIT – BASIC

Application Note 135

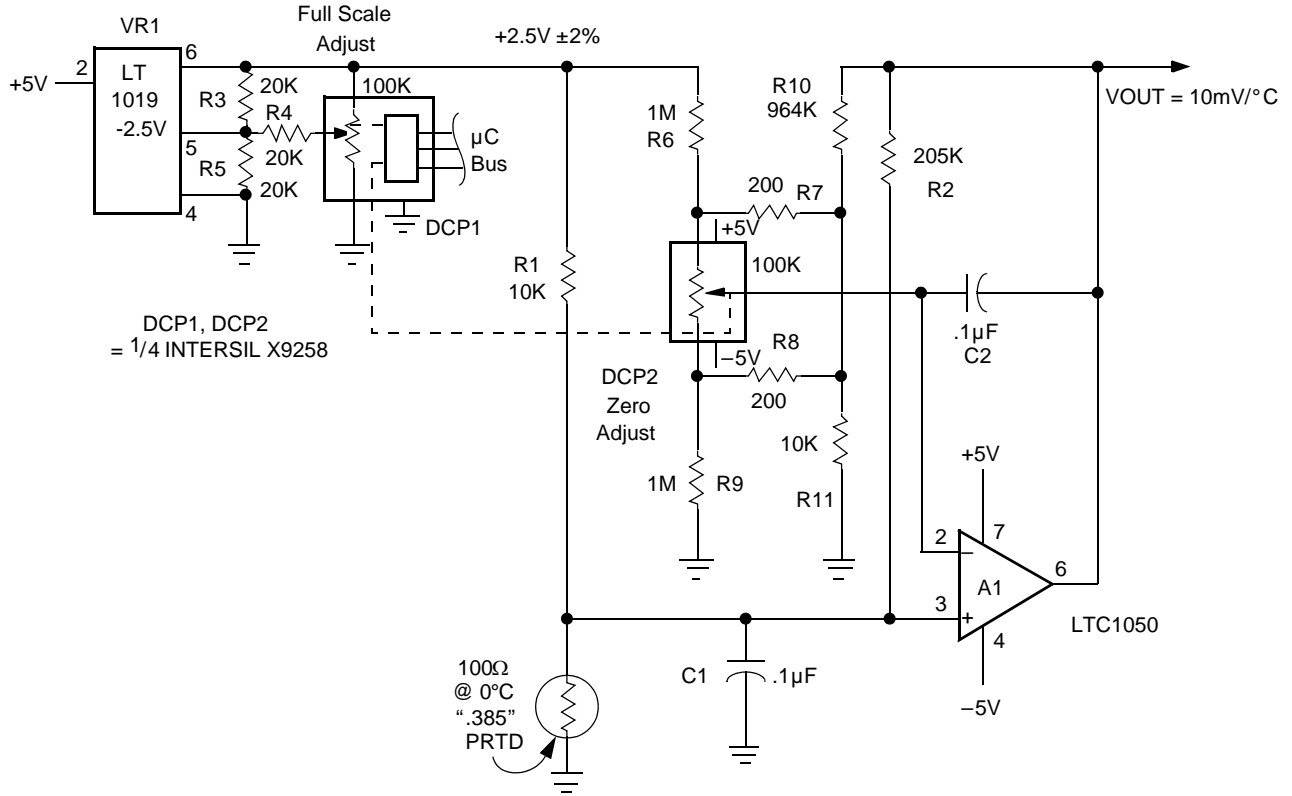

FIGURE 6. PRTD SIGNAL CONDITIONING CIRCUIT – DETAILED

Intersil Corporation reserves the right to make changes in circuit design, software and/or specifications at any time without notice. Accordingly, the reader is cautioned to verify that the Application Note or Technical Brief is current before proceeding.

For information regarding Intersil Corporation and its products, see www.intersil.com